

Load Cell Central

1-800-LOADCEL

WEIGHING INDICATOR SERIES IPE50

Short guide for calibration only

*see user manual 1/2 for the different functioning mode, analog output and setpoints
See user manual 2/2 for special functioning mode and output RS232/485, this manual is available on our Web
site www.800loadcel.com*

(valid from version 07.03)



Load Cell Central follows a policy of continuous improvement and reserves the right to change specifications without notice. © 2014

Load Cell Central
28175 Route 220
Milan, PA 18831

Web: www.800loadcel.com
Email: sales@800loadcel.com

Toll Free: 1-800-562-3235
Ph: 1-570-731-7048
Fax: 1-570-731-7054

POWER SUPPLY & START UP

Do not connect other equipment to the same socket as the one that the adapter is in.
Do not step on or crush the power supply cable

Power supply for IPE50 is from 12 to 25VDC (except IPE50XLI)

The display shows in sequence:

07.xx indicate the version of software if you press the key ->0<-
09.01 09 indicate the type of unit, 01 indicate the metrological software version
XX.YY.ZZ version of the installed software
DGTX name of software
Ex :15001 the max capacity and the round
CloCK if the option timer is installed.

After this, the programmed capacity and minimum division are displayed; then the instrument executes a countdown (self-check) and finally "hi rES" is displayed (in case of non approved instrument) or "LEGAL" and the calibration area (in case of approved instrument).

The indicator has an "auto zero at start-up" function: in other words it means that, with a non approved instrument the display shows the present weight after a few instants, while with an approved instrument "Zero" is shown continuously on the display, until the weight does not re-enter within this tolerance; the auto zero function at start-up may be disabled in the set-up environment (only with non approved instrument); see **SEtuP >> ConFiG >> Param. >> Auto-0 (TECH.MAN.REF.)**

TO stand by the IPE50, keep the C key pressed until the - OFF – message appears on the display; then release the key (the power supply of the sensors 5V is always present).





Press the C key to restart the unit.

To TURN OFF the IPE50, switch off the power supply

5 IPE50 FRONT PANEL KEYS AND INDICATORS

The front panel of the indicator is designed for quick but simple weighing applications. It consists of an LED display with 6 digits 13 mm in height, 6 LED indicators and a keyboard 5 function keys.

LED	FONCTIONS
->0<-	Indicates that the weight detected on the weighing system is near zero, within the interval of $-1/4$ to $+1/4$ of the division.
~	Indicates that the weight is unstable.
NET	Indicates that the displayed weight is a net weight.
SPE	Special mode
W1/ SP1 ou W2 / SP2	W1 or W2 show the functioning with 2 weighing ranges SP1 or SP2 Indicates that the relay 1 or 2 has been enabled.

SCALE KEY	FUNCTION
	<ul style="list-style-type: none"> - Zeros the displayed gross weight, if is within +/- 2 to 50% of the total capacity. (2% max in trade mode) - Cancels the negative tare value.
	<ul style="list-style-type: none"> - If pressed for an instant it carries out the semiautomatic tare. - If pressed at length it allows entering the manual tare from keyboard. - Cancels the negative tare value. - In the numeric input phase it increases the digit to be modified.
	<ul style="list-style-type: none"> - It carries out a specific function of the operating mode set in the set-up environment. - In the numeric input phase it selects the digit to be modified, from left to right.
	<ul style="list-style-type: none"> - It carries out a specific function of the operating mode set in the set-up environment. - In the numeric input phase, it confirms the entry made. - In the SET-UP, it allows to enter a step or to confirm a parameter within a step. - It transmits the data from the serial port dedicated to the printer.
	<ul style="list-style-type: none"> - It turns the instrument in the mode stand by. - In the numeric input phase, it quickly zeros the present value. - In the set-up environment, it allows to exit a step without confirming the change made. - Cancel a tare



INSTALLATION

To obtain the best results it is recommended to install the indicator and the platform (or transducer) in a place with the following conditions:

A flat, level surface on which to rest

Stable and vibration free

Moderate temperature and humidity (15-30°C and 40-70%).

No dust or strong vapours

No draughts

Mains power supply is restricted to 12.... 24Vdc

Make sure the platform is level or that the loading cells are resting evenly

Avoid welding with load cells installed.

When the load cells are used with assembling kits under storage bins or the like, connect the upper and lower supporting plate with a copper wire cable and then earth all the upper plates.

Use waterproof sheaths and couplings in order to protect the load cell cables.

Use a waterproof junction box to connect the cells.

The extension leads of the load cells or signal amplifiers must be screened. In addition they must be laid on their own in a raceway or metal pipe as far away as possible from the power supply cables.

Connection of the cell or amplifier cables on the electrical panel shall be independent and, if possible, connected directly to the indicator's terminal board without laying other cables in the raceway.

Install "RC" filters on the contactor coils, on the solenoid valves and on all devices producing electric disturbances.

If it is possible that condensation could form inside the weight transmitter it is advisable to leave the instrument powered at all times.

Electric protections (fuses etc.) are provided by the technician installing the instrument.

Do not install anywhere where there is the risk of explosion.

All cables must be wound at least once around the ferrite ring before being connected to the terminal board; the cable screen must be left outside of the ferrite and should be connected to the relevant ground pin.

BLOCK DIAGRAM

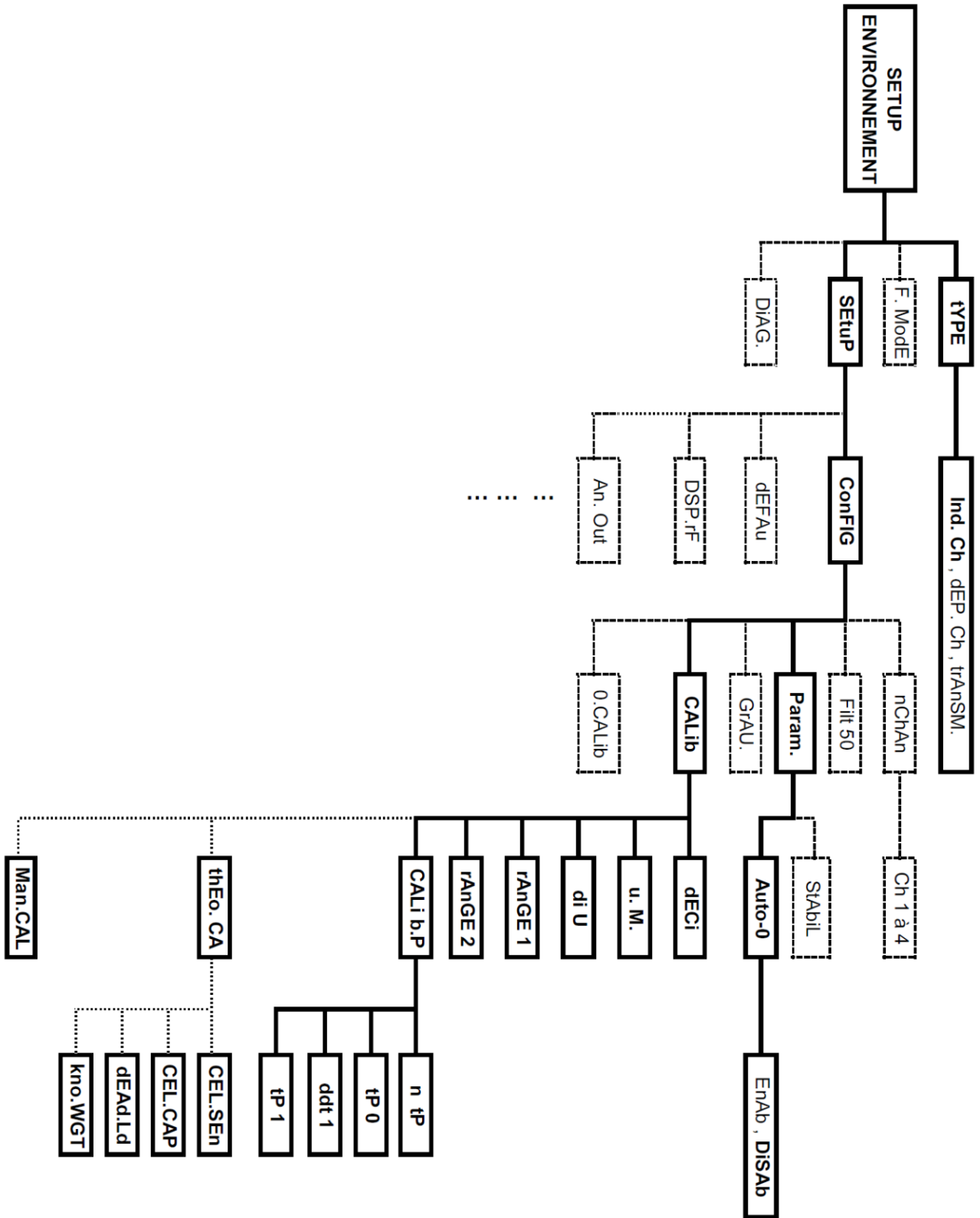

Note :

Only for adjustment the menus in bold are to be configured.

Modify the parameter CONFIG -> Param. -> Auto-0 to DiSAb if you want to forbidden the autozero at the start up.

ADJUSTMENT

Note: The manufacturer parameters of the IPE50 unit are: 2mV/V -> 10.000 per 0.001

Attention: the default calibration parameters will probably not match with your application requirements. You have to calibrate the system according to your needs.

If the unit is in trade-approved mode, you must open the unit to insert the jumper (see jumper CAL page 11 or 13)

To enter the SET-UP environment of the scale, switch on the unit and press the ->T<- key for an instant during the countdown.

To leave the setup environment, press the C key various times until the indicator shows "SAVE?" on the display, confirm with ↵ to memorize and return to weighing.

->0<-	Decreases the selected digit (blinking) or go down.
->T<-	Increases the selected digit (blinking) or go up.
MODE	Selects the digit to be modified (blinking), from left to right.
C	Quickly zeros the displayed value or comes back on the step before.

Valid the new value by pressing the key ↵.

- 1) Enter the SET-UP environment of the scale (when turned on, press the ->T<- key for an instant during the countdown) .
- 2) TypE is displayed.
Press ↵, ind.Ch. is displayed, press ↵
Ind.Ch. Standard using for 1 to 4 independent channels, for DEP.Ch. Using for the connection of 2 to 4 identical sensors on a same system and TrAnSM. see user manual NU-IPE50-1-E-XX
- 3) Select **SEtUP** with key ->T<- then ↵, → **ConFiG** confirm with key ↵ → select **CALib** with key ->T<- and press ↵.
- 4) NChAn is displayed, press ↵ -> Ch x where x is the channel number which must be adjusted.
(for 1 channel or 1 sensor, choose Ch 1 because the sensor must be connected in channel 1 (CELL1))
- 5) ParAM is shown, choose CALib with key ->0<- and press ↵.
- 6) "dECI" step (decimal point) press ↵
The selectable values are 1.0 (a decimal), 1.00 (two decimals), 1.000 (three decimals), 100000 (no decimal); confirm with ↵
(!) 1.0
- 7) "u.M." step press ↵
Set the unit of measure (g, Lb, t, kg) and press ↵
(!) kg
Calibration with load on the system, for theoretical calibration (with loadcell parameters, less accuracy) see paragraph 18)
- 8) "diU" step press ↵
Set the minimum division and press ↵ (selectable values: 1, 2, 5, 10, 20, 50).
Ex: value 1 : the right digit could change from 1 to 1 : 0 ; 1 ; 2 ; 3 ; 4 ; 5 ; 6 ; 7 ; 8 ; 9
value 2 : the right digit could change from 2 to 2 : 0 ; 2 ; 4 ; 6 ; 8
value 5 : the right digit could change between 0 and 5 only
value 10 : the right digit will be always 0 and the second one from the right could change from 1 to

1 : 0 ; 1 ; 2 ; 3 ; 4 ; 5 ; 6 ; 7 ; 8 ; 9

(!) 1

- 9) Select the "rAnGE1" step and press ↵;
Set the total capacity of the scale
if you exceed this value, the message " - - - - - " will be displayed on weighing mode.
Confirm with the ↵ key.
- 10) "rAnGE2" (if the system is a simple range, SET this value to 0) press ↵
Set the capacity of the second range and press ↵
- 11) "CALib.P" ,calibration steps, press ↵
- 12) "ntP" step press ↵
With the ->0<- or ->T<- key set the number of points with which one wants to calibrate (from 1 to 3, with 1 it does the zero point and one weight point) and press ↵
- 13) "tP0" (scale zero point) step and recording of the signal of the loadcell: unload the scale (position "0") and wait a few seconds, then press ↵, the unit will go automatically to the next step after recording the sensor signal.
- 14) "ddt1" (setting first reference weight) step; press ↵, enter the weight value that you are applying on the loadcell and confirm with ↵ key.
- 15) "tP1" (acquisition of first reference weight) step: put the weight (equal at the value on ddt1) on the loadcells, wait a few seconds and press ↵, the unit will go automatically to the next step after recording the sensor signal.
- 16) **If a calibration point has been set**, once the weight acquisition has been made, the display shows for an instant the value of the internal divisions and then the "ntP" step.
If there are various calibration points, repeat the operations for the "ddt2", "tP2", "ddt3", "tP3" points.1
- 17) Once the calibration has been made of all the necessary points, press the C key various times until the indicator shows "SAVE?" in the display: confirm with ↵ to memorize and return to weighing.
N.B.: the calibration points must be increasing (point 1 < point 2 < point 3).
- 18) Theoretical calibration. Press the key ->0<-, "thEo.CA" is displayed, press ↵. Attention, this type of calibration is less accuracy than with real load on the system.
- 19) CEL.SEn , (signal in mV/V of one or many loadcells connected) press ↵. Enter the signal value of one or many loadcells corresponding at the value which will be setting in the step CEL.CAP, attention if many loadcell are connected to the IPE50.
Ex : 1 loadcell of 10t with signal of 2mV/V, you enter 2mV/V for 10t in step CEL.CAP
Ex : 3 loadcells of 10t with signal of 2mV/V, you enter 2mV/V for 3x10t = 30t in step CEL.CAP
Press ↵
- 20) CEL.CAP, (range of one or many loadcells connected) press ↵. Enter the range of one or many loadcells corresponding to the value entered in step CEL.Sen attention if many loadcell are connected to the IPE50.
Ex : 1 loadcell of 10t with signal of 2mV/V, you enter 10t for 2mV/V in step CEL.SEn
Ex : 3 loadcells of 10t with signal of 2mV/V, you enter 3x10= 30t for 2mV/V in step CEL.SEn
Press ↵

21) DEAd.Id (dead load)

If you want to enter the value of the system dead load (empty silo weight for ex) press ↵ in other case press ->0<- (kno.WGt is displayed see paragraph after)

You could enter the weight dead load value with the keys

If no number after the coma has been selected, you could set value from -99999.9 to 99999.9

If 1 number after the coma has been selected, you could set value from -9999.99 to 9999.99

If 2 numbers after the coma has been selected, you could set value from -999.999 to 999.999

If 3 numbers after the coma has been selected, you could set value from -99.9999 to 99.9999

Press ↵

Or

22) Kno.WGt (enter the value of the know weight on the system) in another case press the ->0<- (CEL.Sen is displayed, press key C, th.CAL? is displayed, press ↵ to memorize, rAnGE1 is displayed, see paragraph 23).

If the system is loaded with a know weight, you can set the unit with this weight (with the keys). The unit will memorize the loadcells signal and the weight Press ↵, GET.Wt? is displayed, press ↵.

Wait is displayed for several seconds (the unit memorize the loadcells signal) then Kno.WGt which is blinking and after the unit will go to the step CEN.Sen, press C, th.CAL? is displayed, press ↵, rAnGE1 is displayed.

- 23) Press the C key various times until the indicator shows "SAVE?" in the display:
Confirm with ↵ to memorize and return to weighing.

QUICK CALIBRATION OF ZERO

It is useful to calibrate just the point of ZERO when a permanent tare weight is put onto the platform (for example a roller unit).

- 1) Enter in the SET-UP environment of the scale (when turned on, press for an instant the TARE key).
- 2) Enter in the **SEtuP → ConFiG → 0.CALib** step and press ↵ key (the display shows "CAL.0?").
- 3) Put the tare on the scale and press ↵ key to confirm the operation.
- 4) Once the zero calibration is made, press many times the C key until the indicator shows "SAVE?" in the display: confirm with ↵ to store and return to weighing.

ERROR MESSAGES

While using the indicator, it is possible to incur in the following errors:

MESSAGE	DESCRIPTION
ADC Err	Analog/digital convertor doesn't work. Check the wiring of the loadcells. Measure the signal output of the loadcells between the pins + and - sig, the tension must not exceed 15mV.
PREC.	It is displayed if one tries to calibrate a point without first having confirmed the number of calibration points
ERMOT	Weight unstable during the acquisition of a point during calibration.
ERPNT	During the acquisition of a calibration point a null value has been read by the converter.
Er - 11	Calibration error: a too small sample weight has been used; it is advisable to use a weight equal to at least half of the scale capacity.
Er - 12	Calibration error: the acquired calibration point (tP1 or tP2 or tP3) is equal to the zero point (tP0).
Er - 37	The converter points are less than the instrument's internal divisions. The sensor signal is negative The load has not been applied on the step TP1
Er - 85	It is displayed when the instrument has not yet been calibrated and initialized. Press the ->T<- key when the instrument displays "ERR - 85" to enter the technical set-up environment (with the standard procedure it is not possible) programming of all the parameters of the set-up environment and the calibration.
C.Er.-36	During the calibration some internal negative points have been calculated: - the calibration point is less than the zero point - the signal is negative (check the connections)
C.Er.-37	During the calibration some internal points less than the minimum value have been calculated: - The calibration point is equal to the zero point - A capacity too high in relation to the division has been set
HW-Err	Hardware error. Software not compatible with the installed hardware. The hardware expansion is missing which allows the software to function.

ELECTRICAL CONNECTION

Note for IPE50 DIN and XLI:

With the connector CELL1, it is possible to connect a sensor with 4 or 6 wires (with regulation of the sensor power supply).

With the connectors CELL 2 to 4, the regulation of the sensor power supply can't work (there is only 4 connection)

You must connect at least one sensor on CELL1.

CONNECTION

IPE50 PANEL

Sensor
6 wires connection

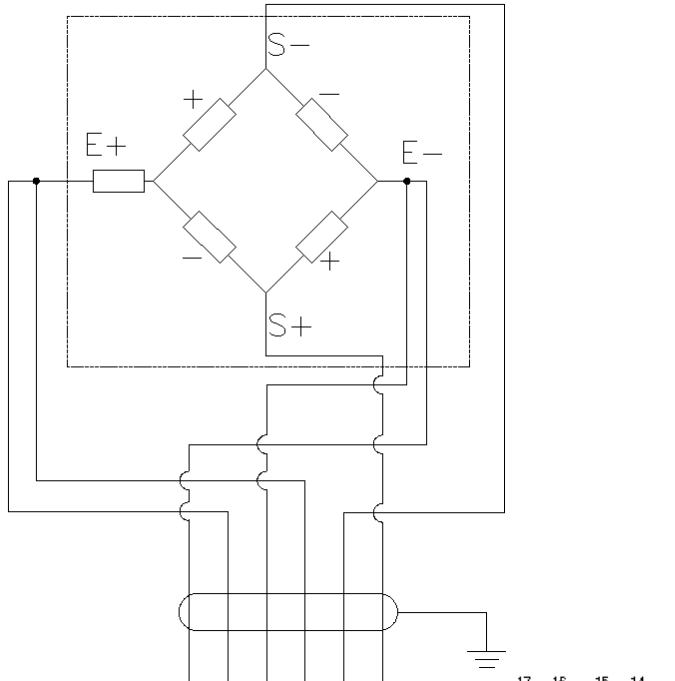

Sensor
4-wire connection

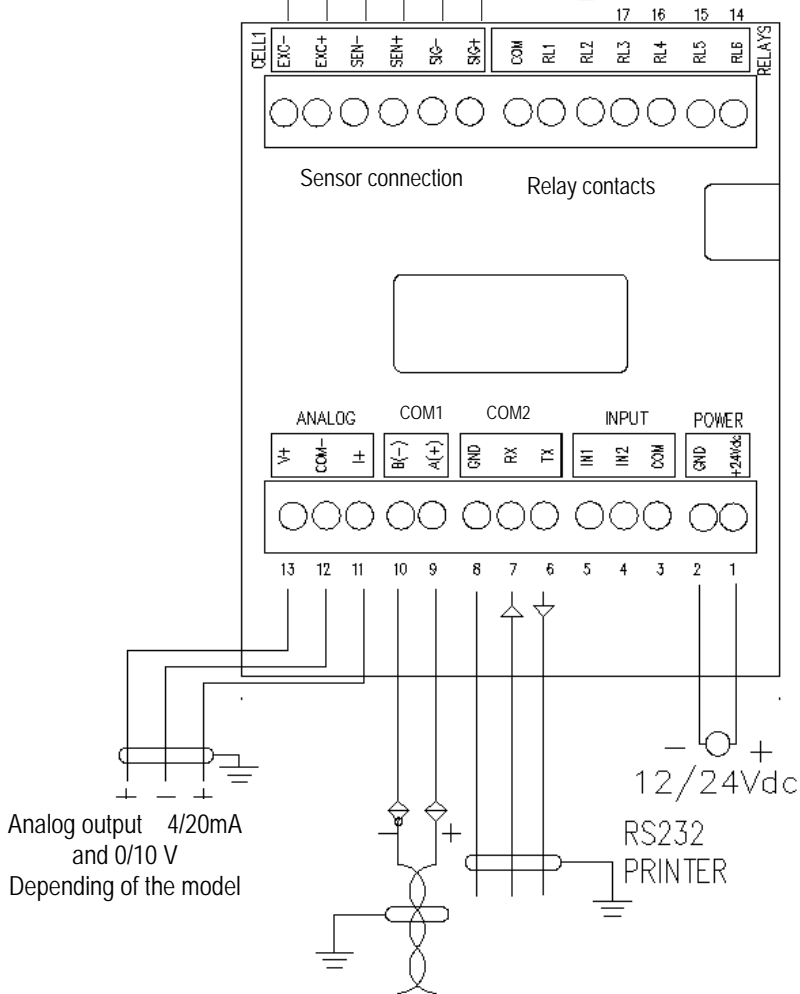
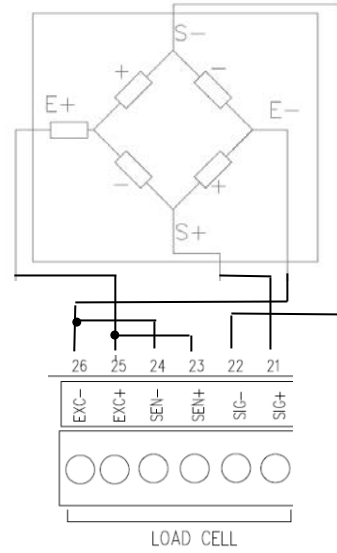

COM1 : RS 232 or 485 depending of the 30 jumpers position on the PCB

COM1 or 2 could be bidirectional or unidirectional in function of the setup

Version IPE50 Panel with PROFIBUS output
 (on this version the analog output is not available)

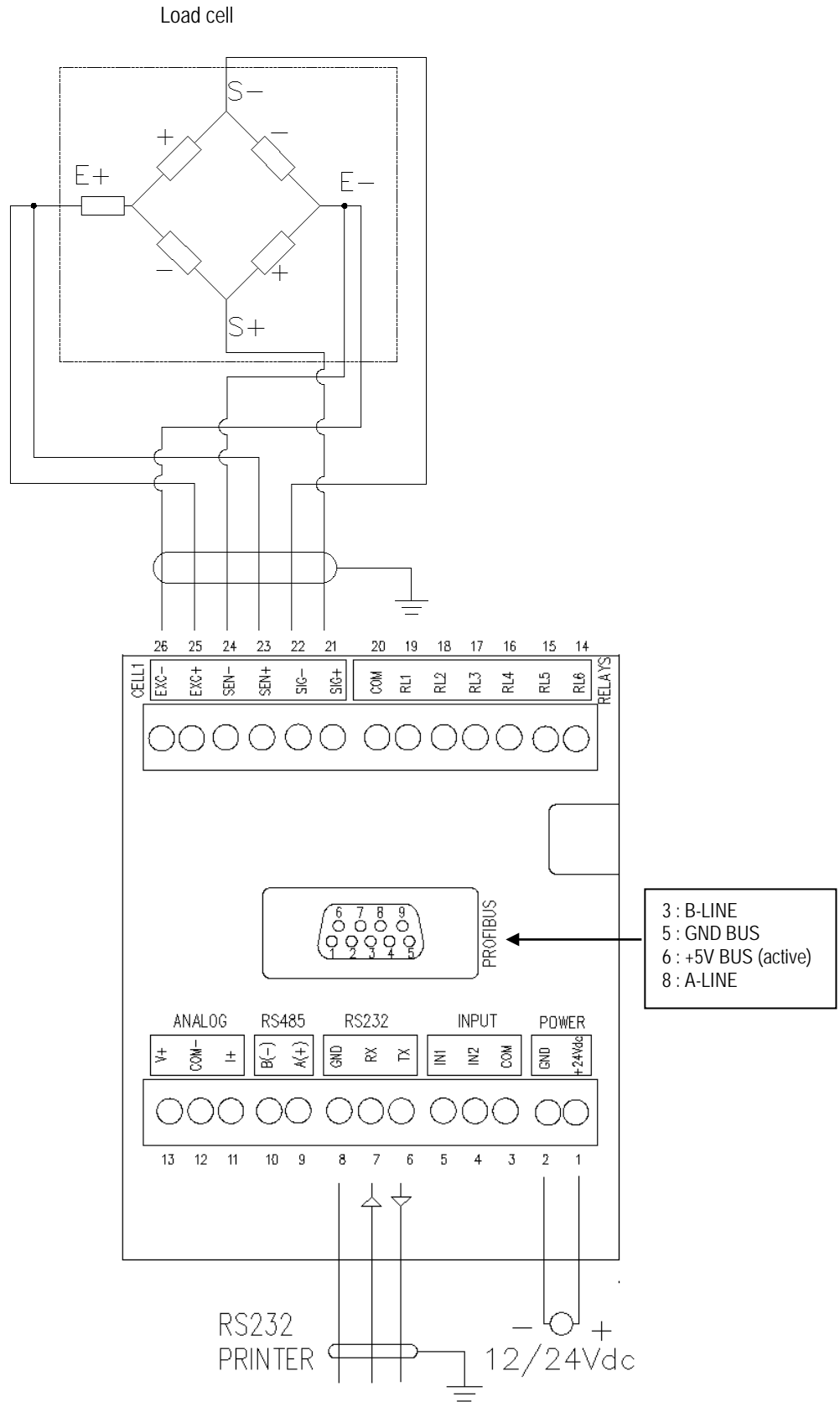

POWER SUPPLY 24 Vdc

- 1 +24Vdc + 12 to 25Vdc / 3.6 W max
- 2 GND - 0 Vdc

Sensor: attention, the power supply of the sensors (5Vdc) and the maximum power is 120mA for example 8 sensors 350 Ohm connected.

Channel 1 for sensor 4 or 6 wires

- + SIG + SIGNAL
- SIG - SIGNAL
- + SEN + SENSE
- SEN - SENSE
- + EXC + EXCITATION
- EXC - EXCITATION



For a 4 wires sensor, please make 2 jumpers between +EXC and +SEN, -EXC and -SEN

Electronic card of the IPE50Panel

Connector BOOT : to install option card timer or alibi memory (DSD)

Jumper CAL opened: trade-approved mode

3 jumpers to select on COM1 RS232 or 485
 3 jumpers between pins 1 and 2 -> RS485
 3 jumpers between pins 2 and 3 -> RS232

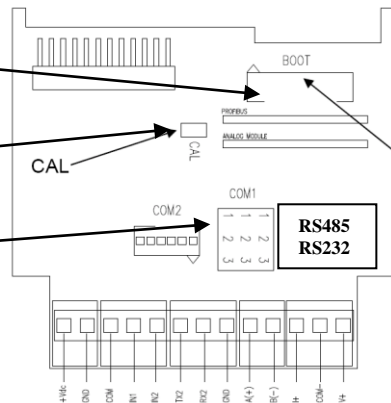

Serial port COM1

- | | | |
|-------|----|-------|
| RS485 | or | RS232 |
| A + | | TX |
| B - | | RX |
| | | GND |

Serial port COM2 RS232

- TX 2
- RX 2
- GND

**(2) static relays contact (power : 48Vdc / 100mA)
(option 6 relays)**

- COM contact commun
- OUT 1 contact relay 1
- OUT 2 contact relay 2
- .
- .
- .
- OUT 6 contact relay 6

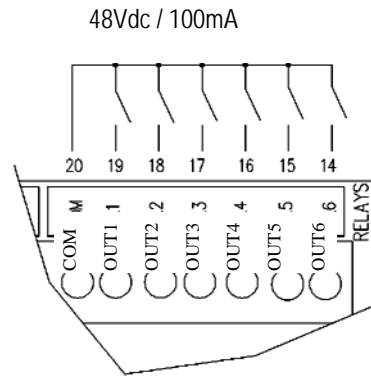

(2) opto-insulated inputs

You must connect the input to the com with a contact and a power supply (12 to 24 VCC). The polarity of the power supply is free on the input / com .

- COM COM
- IN1 input 1
- IN2 input 2

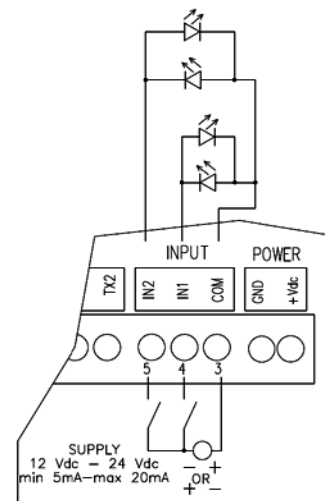

Analog output opto- insulated (0/10V and 4/20mA)

This analog output depends of the model (IPE50P 2S ANA only)
You must set the output you need through the menu An.out (paragraph 13)

- Current (4/20mA) (max load : 300Ω)
- I+ +
- COM -
- Tension (0/10V) (min load: 10kΩ)
- V+ +
- COM -

IPE50 DIN and XLI

Sensors 14
4 wire connection only

Sensor 1 / 6 wire connection
1 sensor must be connected on this channel

LOAD CELL 2, 3, 4

LOAD CELL 1

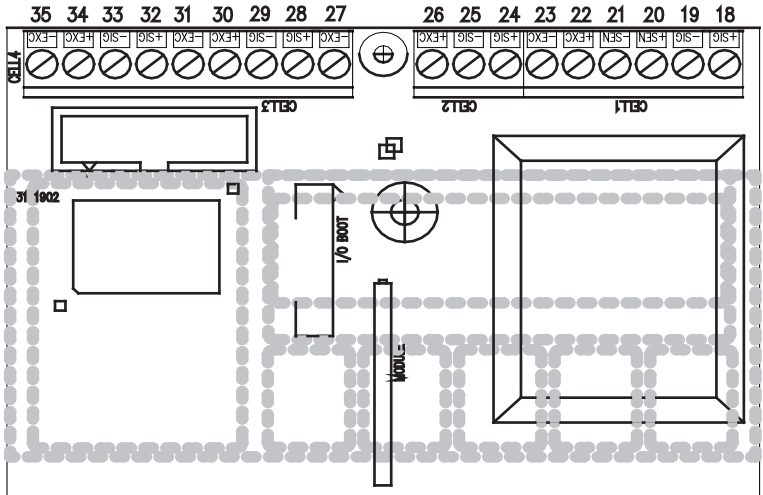
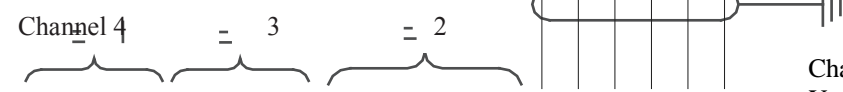
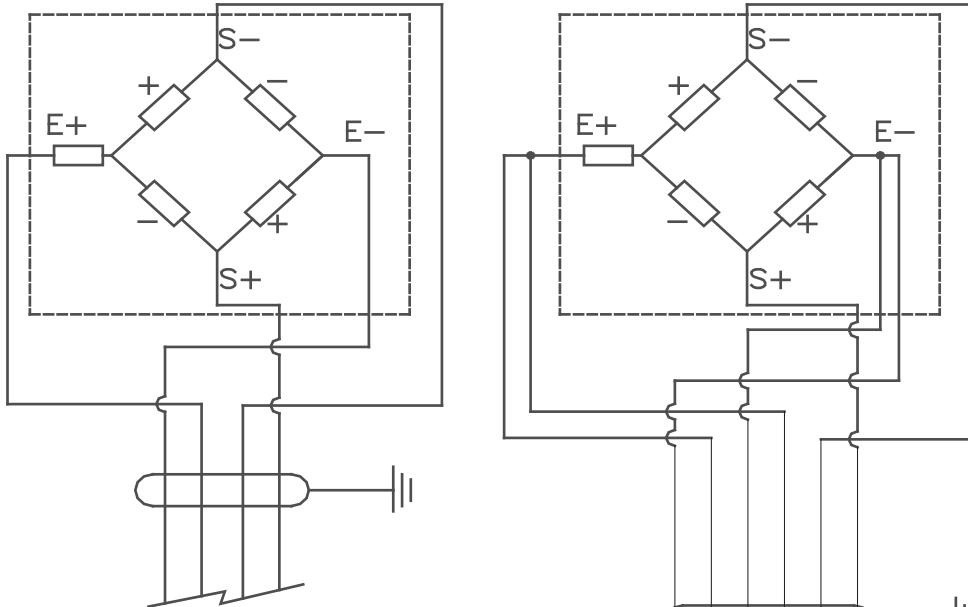

Jumper CAL
opened :
trade
approved

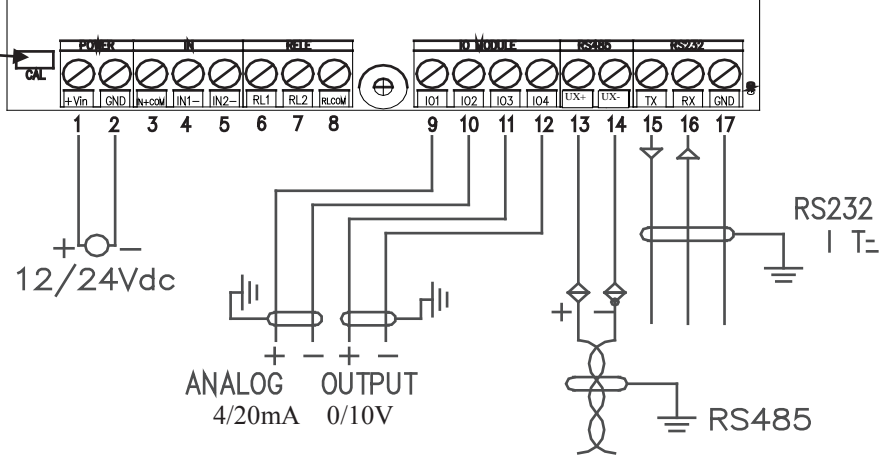

IPE50 DIN and XLI

POWER supply 24VDC (110/220VAC for IPE50 XLI on the power supply cable)

1 +24Vdc + 12 to 25Vdc / 3.6 W max
 2 GND - 0 Vdc

Sensor: attention, the power supply of the sensors (5Vdc) is the same for the 4 channels and the maximum power is 120mA (for all the channels) for example 8 sensors 350 Ohm connected on a same channel or on 4 channels.

Channel 1 for sensor 4 or 6 wires (at least 1 sensor must be connected to this channel)

18 +SIG + SIGNAL
 19 - SIG - SIGNAL
 20 +SEN + SENSE
 21 - SEN - SENSE
 22+ EXC + EXCITATION
 23 - EXC - EXCITATION



For a 4 wires sensor, please make 2 jumpers between +EXC and +SEN, -EXC and -SEN

Channel 2 to 4 for 4-wire sensor

+SIG + SIGNAL
 -SIG - SIGNAL
 + EXC + EXCITATION
 - EXC - EXCITATION

CAL closed : trade approved mode

PC PORT SERIE

RS485

13 UX+
 14 UX-

PNR PORT SERIE

RS232

15 TX
 16 RX
 17 GND

(2) static relays contact (power: 48Vdc / 100mA)

8 COM contact common
 7 RL2 contact relay 2
 6 RL1 contact relay 1

(2) opto-insulated inputs

3 + COM (+ power supply 12 to 24Vdc / 20mA)
 4 -IN1 (- input 1)
 5 -IN2 (- input 2)

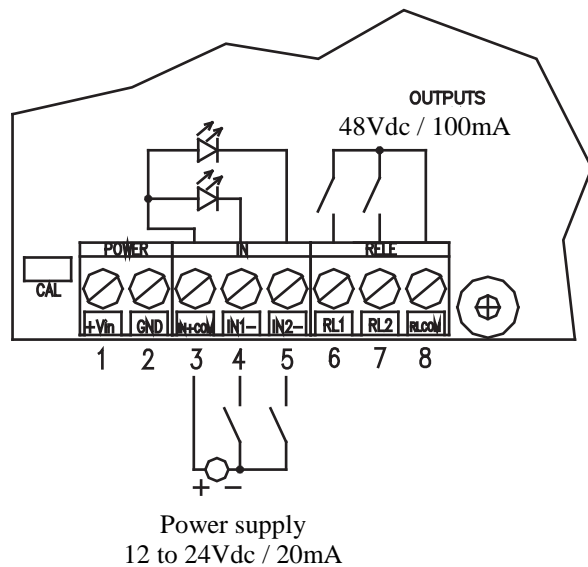

Analog output opto-isolated (0/10V and 4/20mA)

The unit provides the current or voltage output, no external power supply needed.

Non available on version Profibus

Current (4/20mA) (max load : 300Ω)

9 + I
 10 - I

Tension (0/10V) (min load: 10kΩ)

11 + U
 12 - U

RS 485 SERIAL PORT

On the same RS485 network, it is possible to connect up to 32 units

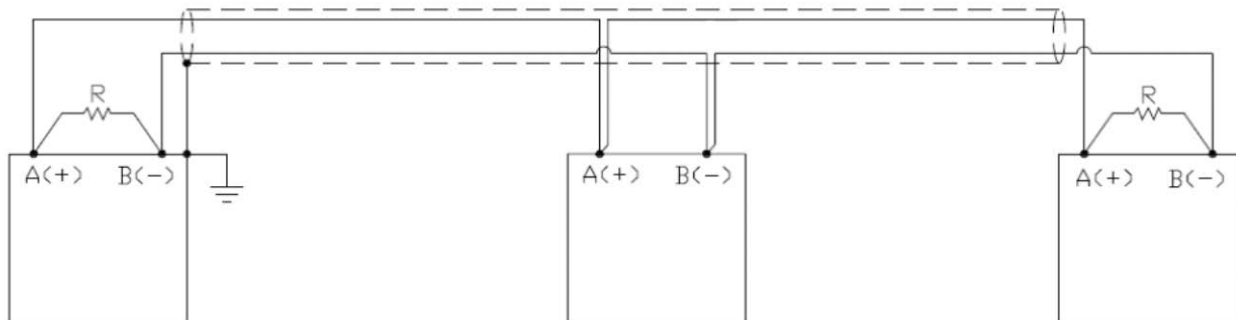

On the RS485 network normally one connects 2 termination resistors of 120 Ohm (shown with "R" in figure). Only on the 2 devices which are at the end of the network.

Use an appropriate cable for RS485 connections, the twisted 2x24 AWG duplex cable, shielded with an external sheathing + aluminium band. The length of the cable should not exceed 1200m.

If there is a transmission problem (long cable) connect a bias resistor of 390 Ohm between B (-) and GND.

If there is still a problem, put a 2 kOhm resistance between terminal A (+) and + supply (+ Vdc).

NU-IPE50-short guide-E-1013